

Pig

Designed by Mike Case

Difficulty: Intermediate
Folding time: 30 minutes

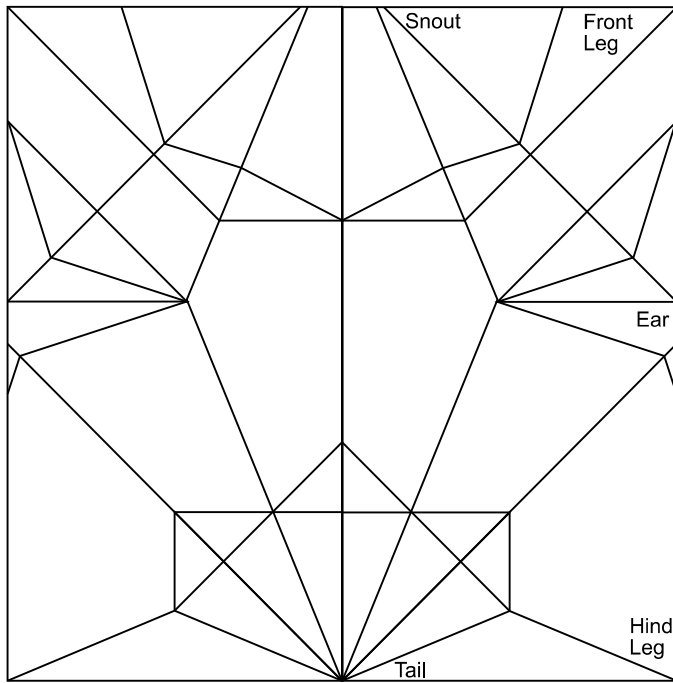
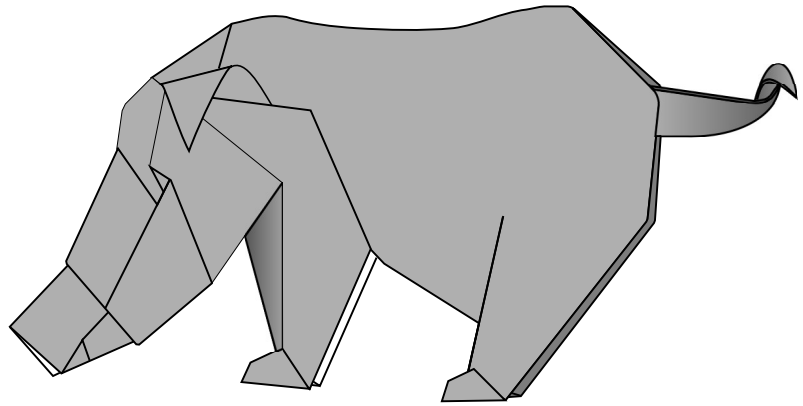

Ratio: 0.65

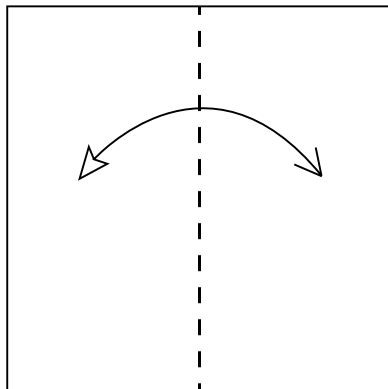
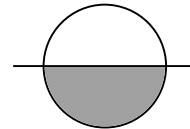
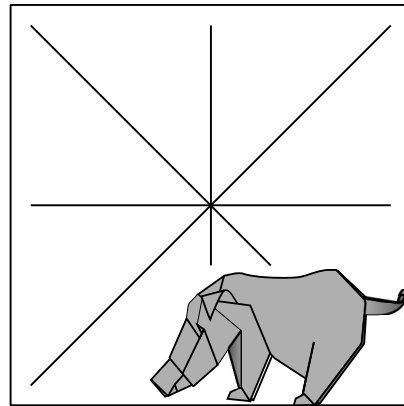

1. Fold in half and unfold.

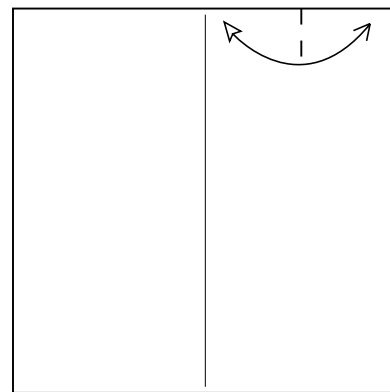

2. Fold the edge to the center and unfold, creasing only at the top.

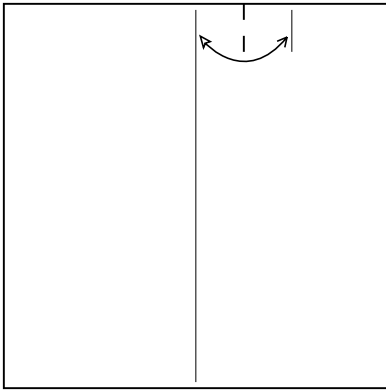

3. Fold the crease made in step 2 to the center and unfold, creasing only at the top.

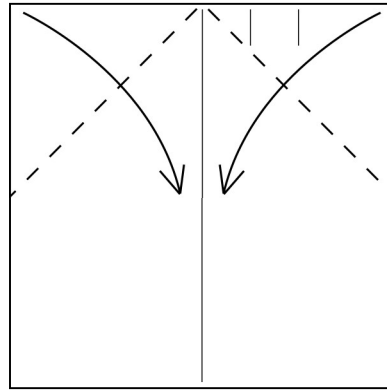

4. Fold the corners to the center.

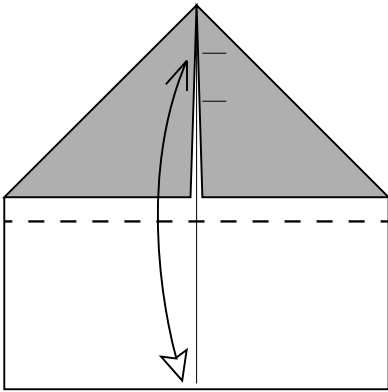

5. Fold the bottom edge to the crease made in step 3 and unfold.

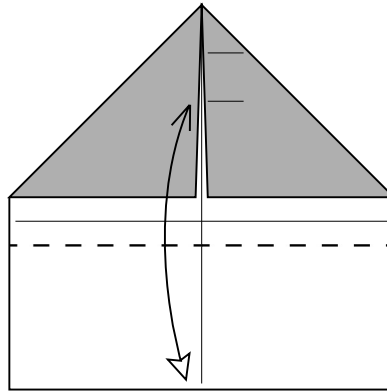

6. Fold the bottom edge to the crease made in step 2 and unfold.

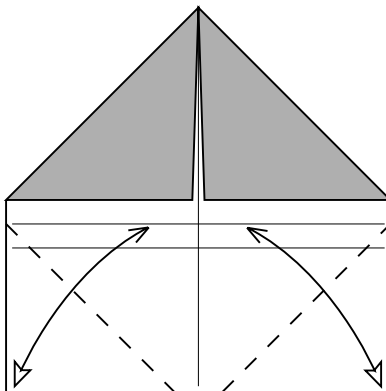

7. Fold the corners up to the crease made in step 5 and unfold.

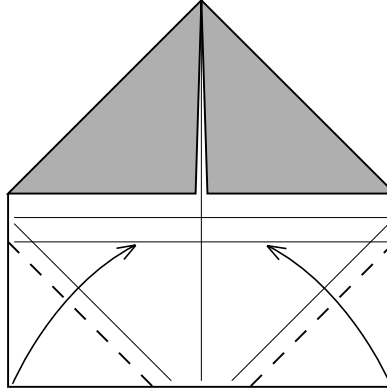

8. Fold the corners up to the crease made in step 6.

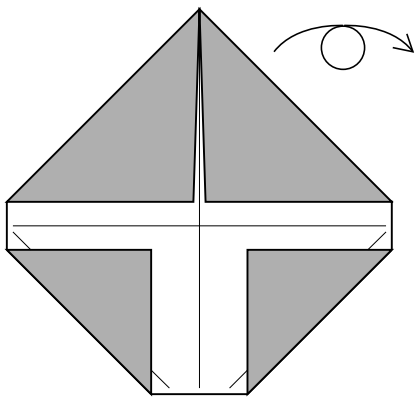

9. Turn the model over side to side.

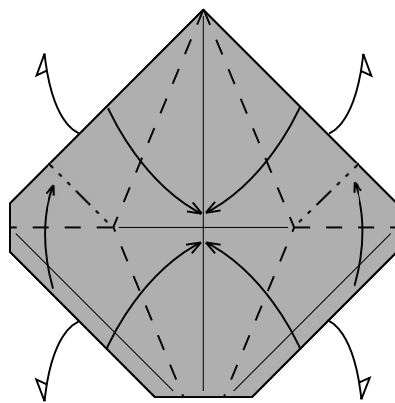

10. Rabbit-ear both sides, allowing the flaps behind to swing out.

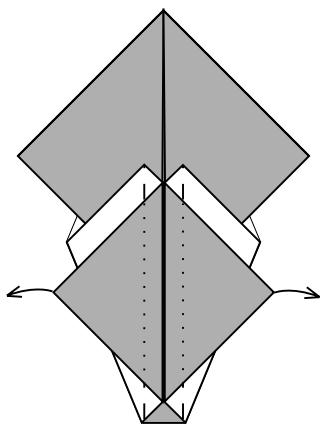

11. Pull the triangular flaps out to the crease made in step 7. Note that this crease and the diagonal crease from the rabbit ear don't quite meet at the bottom.

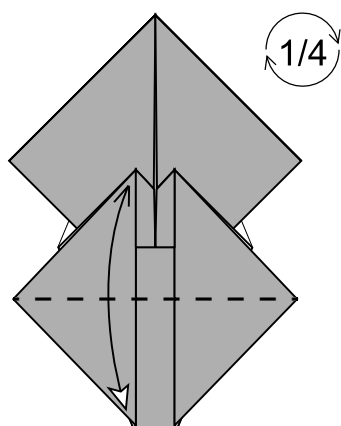

12. Fold and unfold. Rotate a quarter turn.

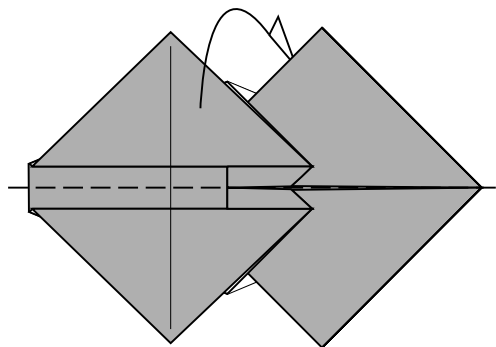

13. Mountain-fold the model in half.

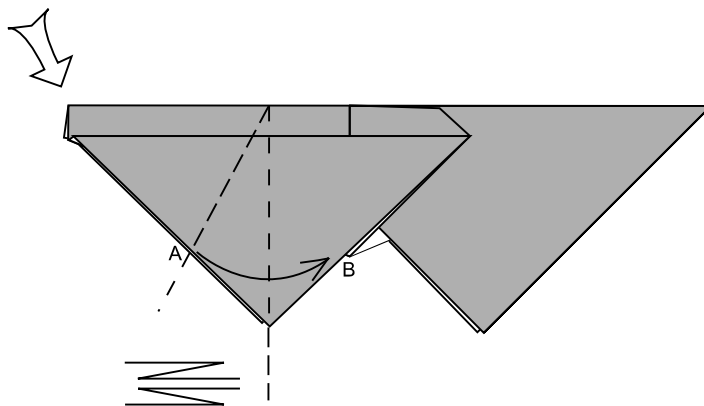

14. Crimp using the crease made in step 12 so that the raw edge A just touches the tip of the white triangle B.

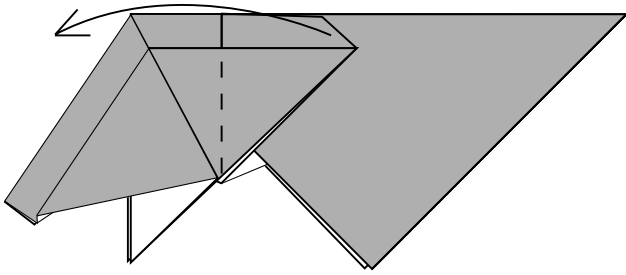

15. Fold the flap to the left. Repeat behind.

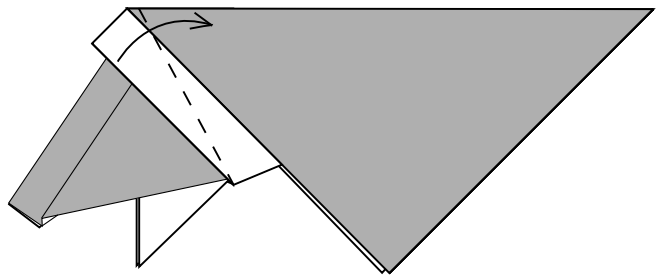

16. Fold to the right so the crease lines up with the edge of the crimp. Repeat behind.

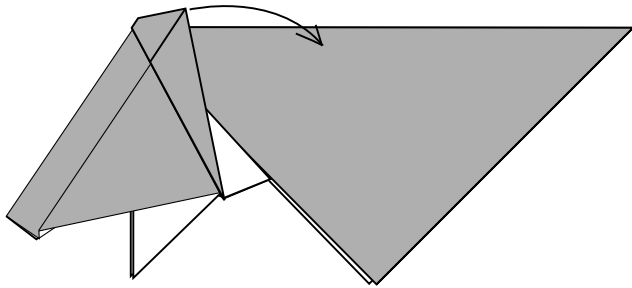

17. Unfold back to step 15. Repeat behind.

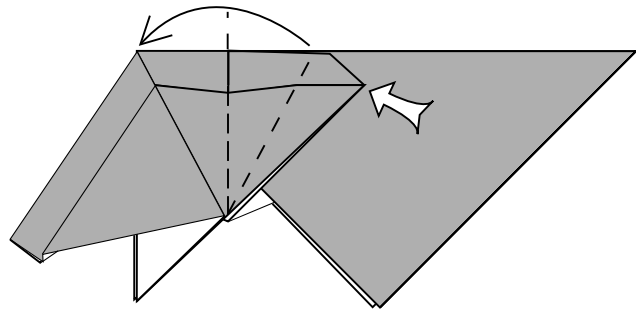

18. Crimp the flap inside using the creases made in steps 15 and 16. Repeat behind.

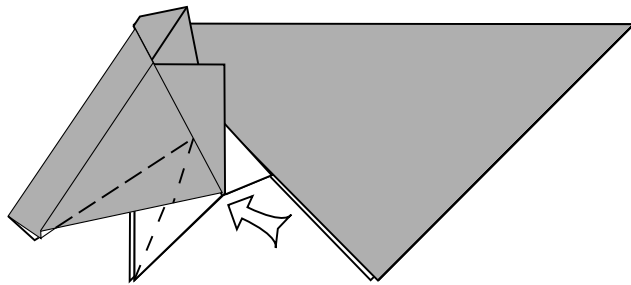

19. Swivel-fold inside. The valley fold on the white triangle is an angle bisector. Repeat behind.

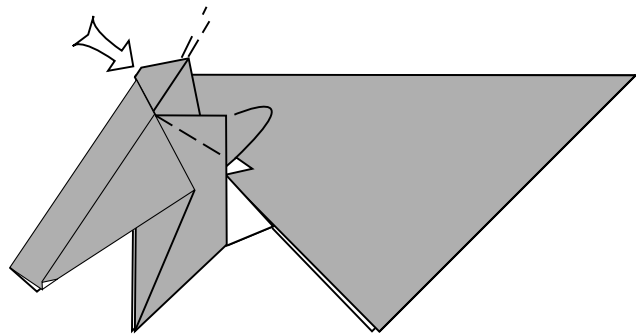

20. Mountain-fold the shoulder. Reverse fold the ear. Repeat behind.

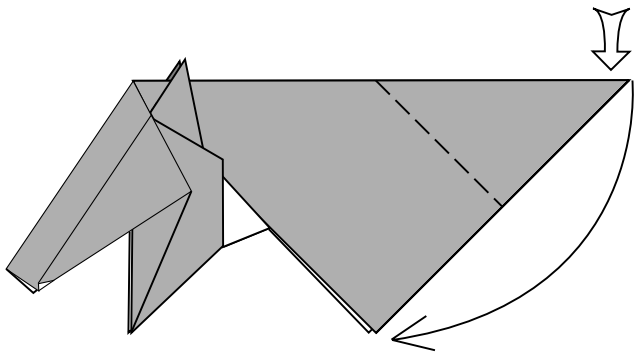

21. Reverse-fold.

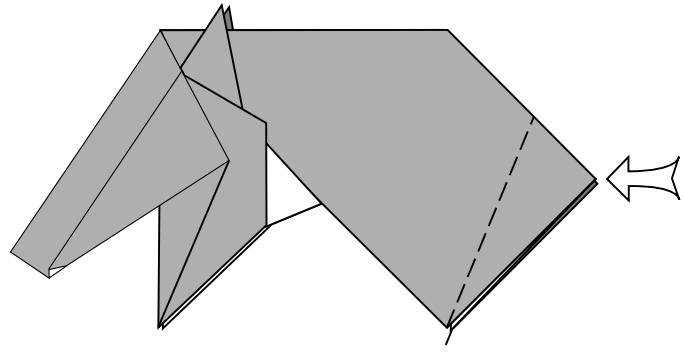

22. Reverse-fold. Repeat behind.

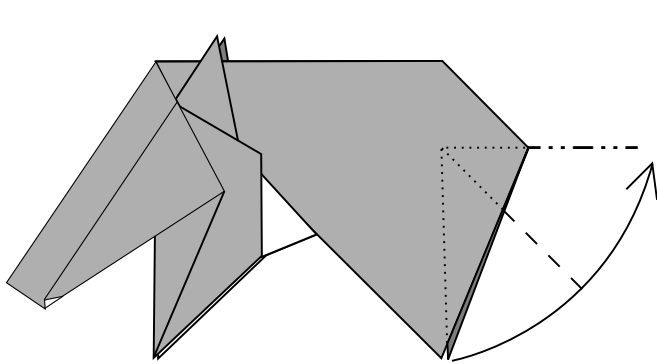

23. Crimp the tail upward.

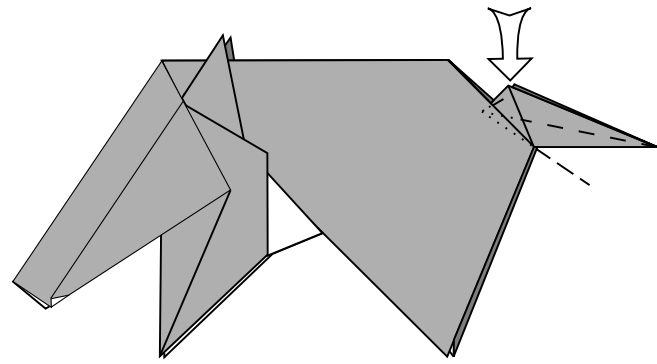

24. Reverse fold to narrow the tail.
Repeat behind.

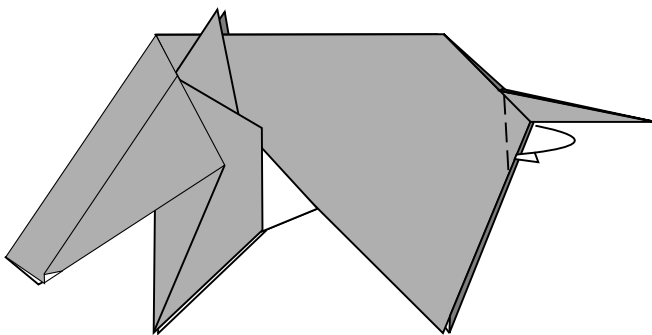

25. Mountain fold. Repeat behind.

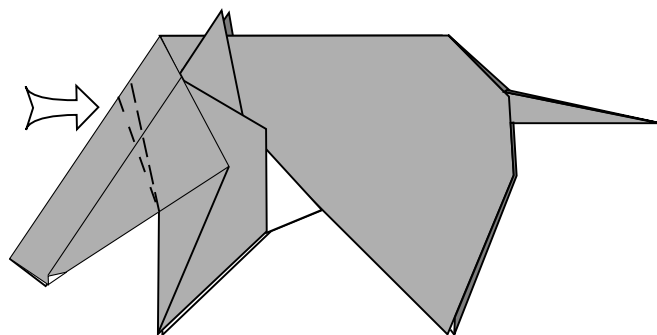

26. Crimp the head.

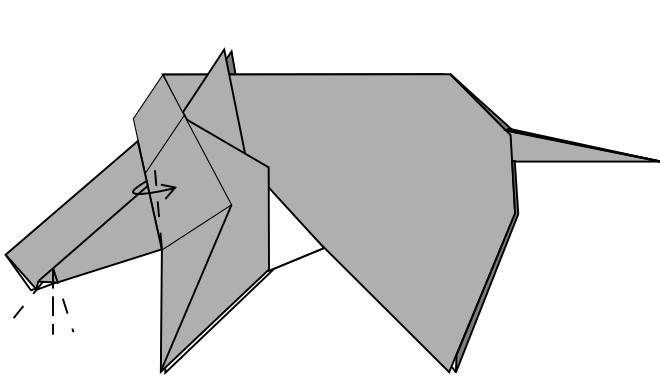

27. Swivel at the tip of the snout to get rid of the small white triangle. Pull out a layer from behind the crimp to form the eye. Repeat behind.

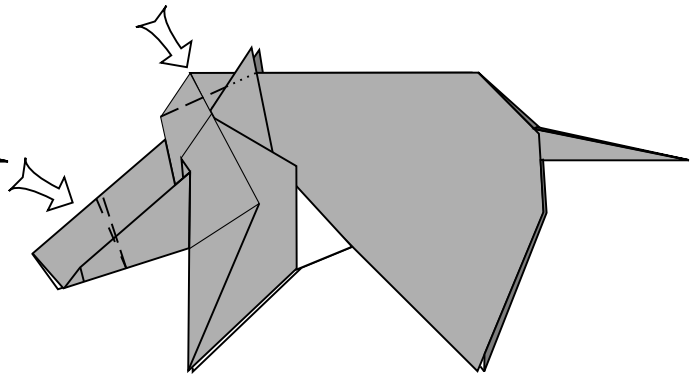

28. Sink the top of the head. Crimp the snout.

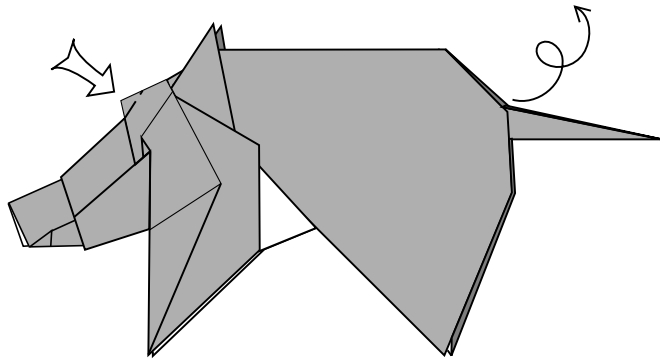

29. Sink the point on the head. Curl the tail.

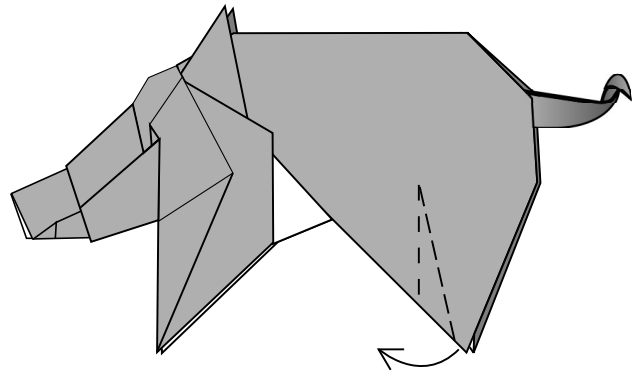

30. Crimp the hind leg forward. Repeat behind. The model is no longer flat.

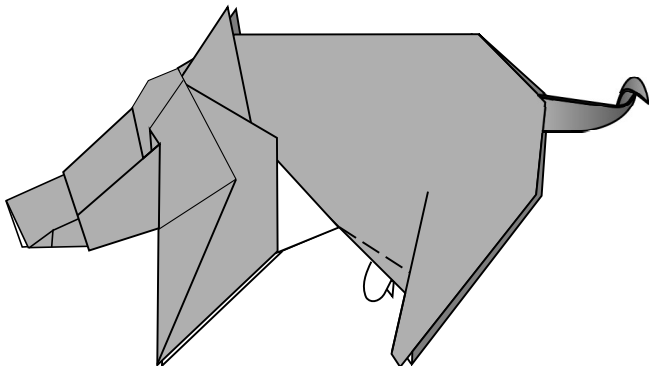

31. Mountain fold, incorporating a swivel fold on the inside of the leg. Repeat behind.

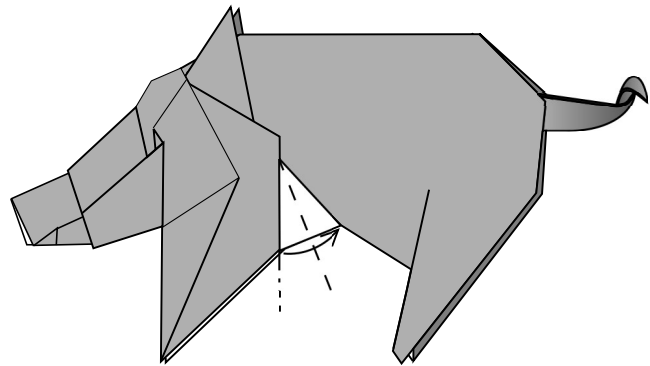

32. Crimp the white triangle. A small mountain fold will help lock the crimp.

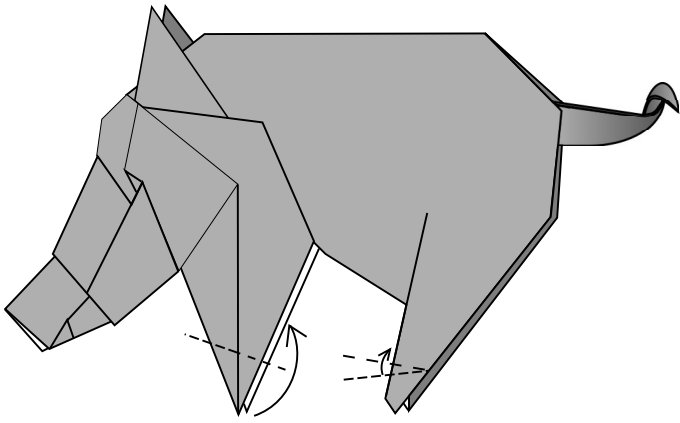

33. Reverse-fold the foreleg. Pleat the hind leg, creating a foot. Repeat behind.

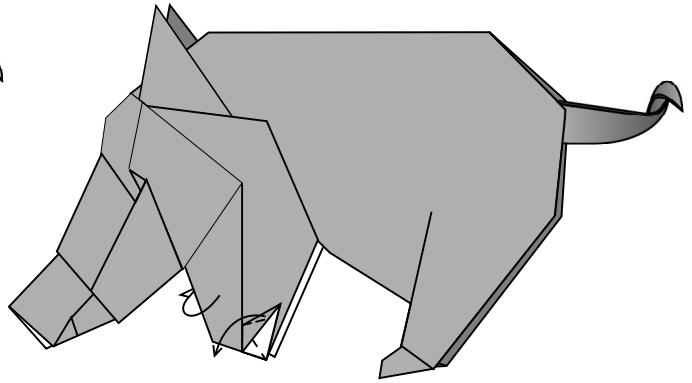

34. Swivel the foot to the left while swinging the front part of the leg into the center of the model. Don't press the foot flat. Repeat behind.

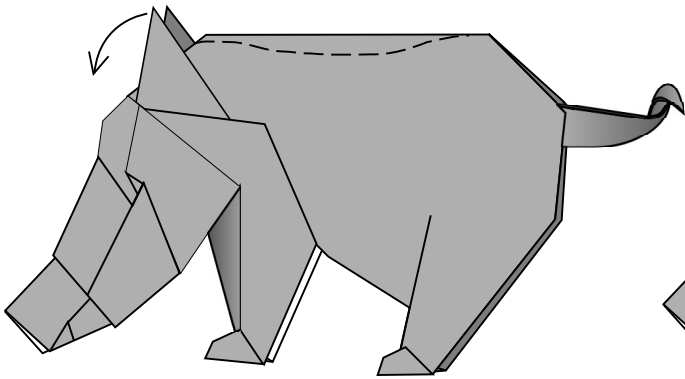

35. Shape the back.

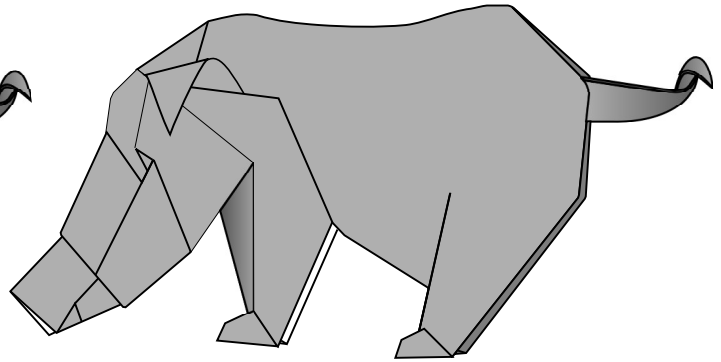

36. The finished pig.